

# Affordable Table for Noninvasively Spinal Disease Treatment



Abdullah Tashtoush\* and Esraa Kamal Rawashdeh

Department of Biomedical Systems and Informatics Engineering, Yarmouk University, Jordan

\*Corresponding author: Abdullah Tashtoush, Department of Biomedical Systems and Informatics Engineering, Yarmouk University, Jordan, Tel: 9622711111; Email: abdullah.t@yu.edu.jo

Submission: June 05, 2018; Published: June 20, 2018

## Abstract

In the light of the ideals and the Hippocratic Oath where the priority is given to the patient safety. Hippocratic idea to modern surgery had been applied by many orthopedic specialists. Consequently; corsets and spinal traction was gained broader popularity. In view of the fact that spinal disease was therapeutic based on mechanical traction techniques. So far and credit for modern technology, disk rehabilitation table (DRT) is made in many different stylish and look, but the figure of merit was comfortable, luxury and fancy, which is made such medical instruments excessive out of most patients money-wise capability. Whereas the guidance of the national institute for health and clinical excellence (NICE), which is stressed on caring patient with low cost and high efficiency. It is a well-stated fact that cares for patients does not mean resuscitating the terminally ill, but it is required to act with care and compassion in the benefit of patient. Therefore, this work presents affordable medical instrument for back-pain patients that is enhanced nonsurgical treatment for various spinal diseases based on mechanical traction device. The proposed instrument is very safe and very effective particularly when the disease discovered before it becomes acute or even chronic inflammation.

**Keywords:** Auto-traction, Degenerated discs; Hippocratic oath; Noninvasive

## Introduction

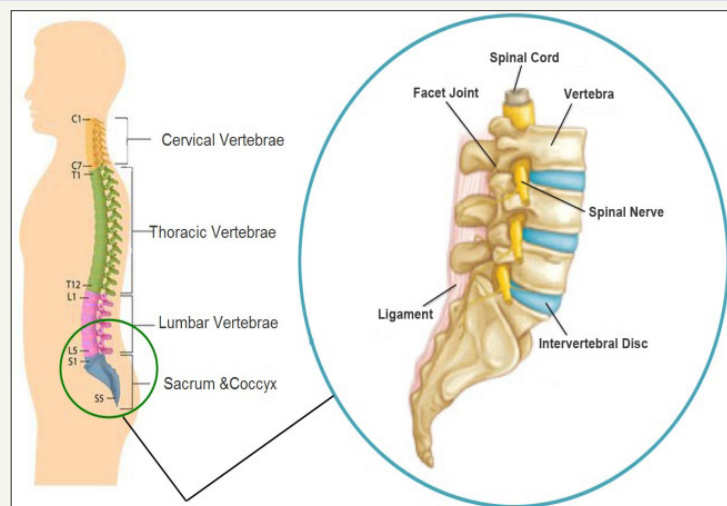

Figure 1: Anatomy of lower back spine, courtesy of shutterstock.

Far away from now, spinal diseases were considered and by a lot of medical doctors and orthopedic specialists. In 1789, modern surgery was gotten involved to improve spinal therapy by JA Venel. Then after, corsets and methods of suspension were pronounced to cure disk disease. In 1883, the suspension technique was used by Osip Mochutkovsky, who was invented a disk rehabilitation table. In 1893, suspension technique got more reliable and developed by

VM Bekhterev, who was combined body suspension with cervical traction. In 1897, Gilles de la Tourette as a neurological specialist was employed spinal traction treatment clinically. At the present time, the mechanical traction technique has become the most preferable technique recommended by neurologists and orthopedic specialists for patients for the great specialists and physician efforts [1]. As a result of medical treatment, both effects; therapeutic and

adverse, can be occurred. The physician has important role to make the right decision, and then after recommending to the patient what is the best for his status on the light of the medical treatment results of Figure 1 illustrates the lumbar spine structure, where most of the back pain comes from. Other possibilities of the back pain occur due to lack or consumption of spongy pads. Herniation of the lower back spine can be occurred accidentally, therefore, caution should be highly considered by people. Speaking of which, an ounce of prevention is worth a pound of cure. To get rid of such pain the mechanical traction along with vibration are the most recommended by physician and specialists [2].

### Literature Survey

Around 3,000 BC the Egyptian papyri coined traction idea. In 1862; Edwin Smith was unveiled this idea to reduce pack pain and heel some less serious conditions. Distraction or skeletal traction is one of the most primaeval medical treatments known and still [3]. In 1933, W Gayle Crutchfield has pioneered an innovative gadget, which is cranial tongs that uses for vertebral column alignment to bring it up to normal condition. Recently, clinical care and medical centers adopted this instrument to externally applied spinal traction [4]. In 1974, a new spinal traction technique was developed by creating what is known auto-traction, which coined by Scandinavian physician Gertrude Lind. Spinal auto-traction technique has led to cure patients suffering from disc prolapses noninvasively and keep away from surgical discectomy. In 1985, X-ray computed tomography (CT) technique has evaluated and examined auto-traction modality; the conclusion was promising-results and beneficial [5]. In 1991, Pelvic traction as a classics technique, which is based on the use of CT technique modality had become less and less because of lack of efficacy [6].

Moreover, a new device called VaxD, which based on, controlled by a pneumatic system, which is coined by Dr Allan Dyer, 1991, who was originally developed and pioneered nonsurgical spinal decompression. An abrupt involuntary muscular contraction and cramp is reduced using CT modality.

In 2004, a latest version called G2 developed from Vax-D by Medical Technologies modality, which traditional techniques with modern technology. Non-surgical spinal decompression technique as a process to relief the pressure the spinal column; still be considered by a lot of scientist and physicians and one of their most concerns [6]. Scientists' efforts have led to have more advance tables, such as Roman Chair, Rolls-Royce, Flexion Table, but suffering from high cost and complexity for the end user.

### Mechanical traction theory

Mechanical traction is an ancient technique was utilized to cure patient form back pain. Credit for modern tools and facilities it has been developed and upgraded to achieve its aim efficiently and accurately. Back pain and human weakness are strongly related to the pressure on the nerve roots that arises due to disc reducing thickness and bone spurs accumulate. Getting rid of this pain can be achieved by augmenting joint space, which leads to alleviate the pressure on the nerve roots. Having this done by stretching a positive test is concluded. The main parameter on this process is the controllable applied pressure on the patient [7].

Surgeries in both categories; invasive and non-invasive, have been devoted a lot of efforts to lay down protocols and standards based on surgical management to keep away from any complications it may occur during the modern techniques [8].

**Lumbar degenerative disc disease (LDDD) disorder:** Lumbar degenerative disc disease (LDDD) disorder can be observed by different features developing gradually, damage, and disable organs. Degenerative LDDD disorder is proceeding step by step one damage in the pads is enough to have this disease occurred, as shown in Figure 2. As LDDD disorder occurs gradually, therefore, aging is mostly the main reason beyond LDDD disorder happening due to either the loss of fluid from in between pads or casualty spine column. The most difficulty in determining LDDD disorder is referring to not presence specific symptoms and signs, even it can be existed where no pain [9].



**Figure 2:** Model of a healthy spine [5].

In serious accidents, spine column is probably the most organs to be exposed to injury and then herniated disc happened. In the

main, inflammation and abnormal micro-motion instability are the source of pain.

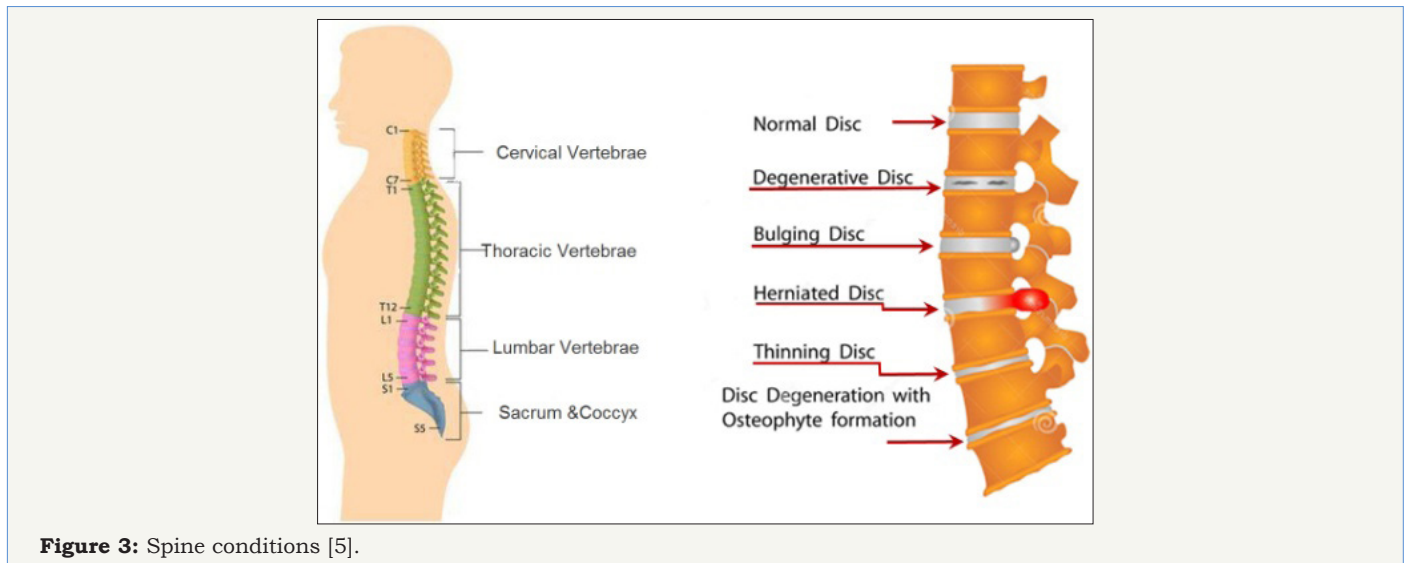

**Figure 3:** Spine conditions [5].

**Back pain treatments:** Temperature can be started to relief pain, along with sports and exercises, which are initially recommended by the physician for a vigorous back pain. In such situation, besides less pain and low cost, the extensive treatments can be avoided. Then after, treatments can be changed and replaced in the light of the patient condition and age. Figure 3 illustrates the different types of back pain and their locations.

Back pain can't be ignored as by time it can be developed to be chronic inflammation, therefore; this serious issue should be treated in early stages without drugs. Thus; the patient can control the pain before the pain controls the patient.

As stated by the Mayo Clinic, when the back pain has become chronic inflammation disease, particularly, due to ankylosing spondylitis, the back pain continues firmly for more than three months, afterwards the back pain and stiffness become more worst; particularly, when it is associating with less activity and less moving. Consequently; the best therapy in such situation can be attaining by physical activity and exercise [10].

**Invasive and Non-Invasive Surgeries:** Spine patient outcomes research trial (SPORT) has performed a lot of analysis and studies on either surgery or nonsurgical treatment and has come out with great recommendations and treatment protocols for both techniques.

## Methodology

The Disc Rehabilitation Table (DRT) abed working principle of action and in which the vertebral column moves through it. DRT is divided into two parts; one fix and the other part movable, moves to separate the vertebrae from each other, as has been shown before [11].

The structure of the spinal column is built of pads; disks, which is made of two layers softer cartilage that be all around tough cartilage as shown in Figure 2. The goal of these pads is to absorb external shocks and thus make the spine more flexible. Therefore,

the biomedical device; DRT, which has been built up to relief pain and stiffness; effectively, with low cost, significantly, and with paying full attention to biosafety and biosecurity.

## Theory and components

The biomedical device that has been built up is made of some components, which aforementioned in [11], the other component that has been added to the device is the strain gauge, as linear position transducer. Strain gauge sensors is a linear displacement sensor, which move in one direction along a single axis. In such sensor, the output is a reflection to the movement of an object with respect to a reference point. The linearity in this device refer to the direction of motion, which measures in millimeters, and the sign of the voltage is referring to the direction of the movements inwards or outwards of the reference point; accordingly.

A variety of measuring principles are available to use in measurement instruments; electronically. The displacement of mechanical gauge sensor is in range of 101.6-304.8 micrometers are typical, which leads to make the deformations in electronic sensors is so tiny. In the mechanical gauge sensor, the principle of measurement is based on having the output electrically quantifiable proportional to the input variable; (i.e. the physical variable; the force), with no external power source.

Crediting to minimal deformation in the gauge sensor; the electronic measurements show change rapidly with time; speed of response, associating with low material strain and the ability to withstand wear, force, or damage.

A displacement linear sensor, which is used in this device is electric strain gauge module WYJ-V-150 mm for pile driver for pile driver to detect the strain, as shown in Figure 4, with the amplifier and potentiometer on the board to adjust the measured results. The simplicity of the gauge sensor is confined in attaining the result readily through connecting it to Arduino; i.e. A Tmega328, as shown in Figure 5.





Figure 4: WYJ-V-150 mm displacement-sensors linear sensors.

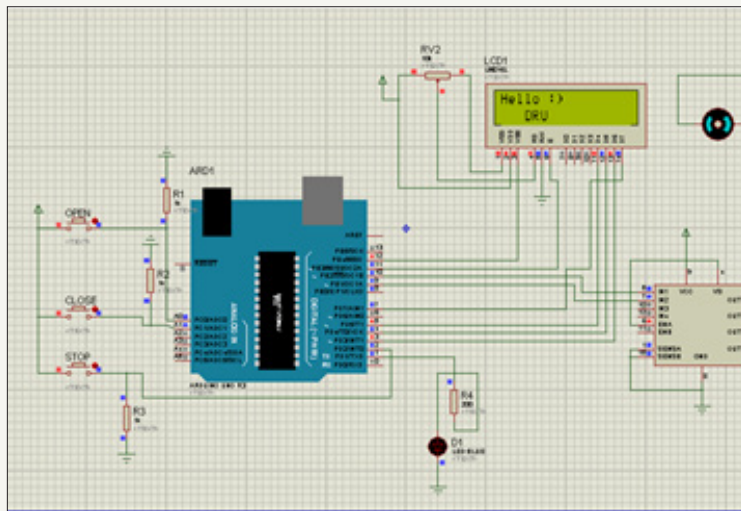

Figure 5: DRT design.

The specification of the gauge sensor; WYJ Miniature hinge series linear displacement electronic 25mm-300mm, 2mm at both ends buffer stroke, precision 0.25%-0.08% full-scale, shell surface, drift-free, and long life. Sealing rating of up to IP67, which are waterproof and protected from dust and sand, have a direct outlet and five-pin plug socket out two options, can be applied in biomedical devices, and it is convenient for small space; i.e. human spine, due to its allowable limits velocity; horizontal installation of 2m/s.

A linear encoder is a sensor paired with a scale that encodes position. The sensor reads the scale to change the encoded position into electrical signal, either an analog or digital signal, which can then be decoded into position by motion controller; in this case. The simplest form of an electronic pressure measurement system is the gauge sensor, which converts the physical variable into an electronically quantified variable.

The output signals are inconstant, and they are not compensated internally, so they are not caused the output to conform to a standard. In explicitly, the gauge sensor attached between the fixed part of the device and movable one then bonded electrically. The characteristic output signals from gauge sensor; i.e. WYJ, are in the range of 10-100 mV, depending on the sensor type.

**Affordable disc rehabilitation table (DRT):** The Disc Rehabilitation Table (DRT) or Disc Dragging Table (DDT) is abed working principle of action and in which the vertebrae of vertebral column move through it. DRT is divided into two parts; one fix and the other part is movable, moves to separate the vertebrae from each other, as shown in Figure 6.



Figure 6: The proposed medical instrument.

Physicians always have recommended to patients who have back pain to start therapy by self-motivation to restore readily

their health by exercising and getting physical therapy, the lack of knowledge and unavailability of tools make it hard to let patients to accomplish and do such so. Therefore, this device is affordable for all level of patient's income, besides it will strongly contribute to improve the treatment of the disc disease safely, effectively and easily to use.

Moreover, it will come over the existed devices' problems such as cost and complications. The main idea behind the powerful of the proposed DRT besides its cheapest price, it is using auto-traction device that will avoid the complications and other aforementioned problems [11].

Auto traction idea intended for medical therapies appear in various reports through the 20th century, and developed by Scandinavian physician Gertrude Lind, who concluded that a lot of patients, who are suffering from back pain can definitely get rid of pain using nonsurgical spinal decompression techniques. The importance of using auto traction device is not only less pain but also aiding the patient to improve his daily behavior.

#### A. The physician mission

The doctor bely the patient to the bed by two belts one for upper part and for lower part. Then the movable part starts to move in order to space between the vertebrae. The main two control systems are duration that patient will lay down and the level of force. The system has the capability to run in two modes either continuous or intermittent mode.

#### B. The device mission

DRT is capable to perform more than one function simultaneously besides making space between vertebrae, DRT can support ligaments and tendons and a stretching the spine to take pressure off compressed discs.

#### C. DRT advantages

Disc Rehabilitation Table (DRT) has several advantages, it separates between vertebrae that will help in balancing and relaxing for back muscles and strengthen weak muscle which affected by the disc disease. DRT supports ligaments and tendons, and other a lot of disc treatments.

#### D. DRT disadvantages

Normally there is no limitation of using this device, except for patients with osteoporosis, pregnant women, and cancer.

## Results and Discussion

The proposed table was met the expectation and goal, it is capable to be using in physical therapy for disc disease for its noninvasive method. DRT is simple, user-friendly and comfortable for the patients. The device is great for any patient with Lumbar spinal stenosis, Muscle spasms, Herniated disc, Degenerative disc, Sciatica, and Post-surgical patients. DRT is a wonderful device for anyone due to natural, safe, non-invasive. Moreover, DRT helps in muscle relaxation, increase blood circulation, and no side effects.

## Conclusion

Most of the back pain is chronic inflammation that should not be oft-ignored, as the more time intentionally or unintentionally disregard, this will lead to arthritis ankylosing spondylitis, due to fusion of the vertebrae.

DRT was designed and implemented as a simple, and user-friendly lumbar traction device. The target users of the device are people who suffer from general disc disease. The DRT system shows expected results and meet the specification of the design properly. As aforementioned there is no permanent chemical treatment for disc, there are painkillers but has several risks associated with. Therefore, this idea came to serve people who have a simple or complicated disc without any risk or side effects.

By means of mechanical traction, one can achieve in minutes or hours what might take days or weeks in bed. The main objective from disc rehabilitation table is to make space between lumbar and cervical vertebrae that can help strengthen spine column and its components.

## Acknowledgment

Dr. Adel Tarawneh; certificate in Chinese medicine, and Certificate in Environment science also have a large medical center in the United States, and Kamal Rawashdeh for their contributions.

## References

- Lizhen W, Wei Y, Pin X, Shan T, Jian M, et al. (2014) Effect of combining traction and vibration on back muscles, heart rate and blood pressure. *Med Eng & Phys.*
- Shtrenshis MV (1997) The history of modern spinal traction with particular reference to neural disorders. *Spinal Cord* 35(3): 13946.
- Peter F Ullrich (2012) Lumbar spine anatomy and pain.
- Vert Mooney (2006) Rehabilitation and exercise for a healthy back.
- Gillström P, Ericson K, Hindmarsh T (1985) Computed tomography examination of the influence of auto- traction on herniation of the lumbar disc. *Archives of orthopaedic and traumatic surgery* 104(5): 289-293.
- Lippincott W, Wilkins (2013) Surgery vs. non- invasive treatment-which is better for herniated discs? *Science Daily.*
- Hoppenfeld, Stanley. *Physical examination of the spine & extremities*, pp: 126- 127.
- Kevin W, Annunziato A, Dianne B, Nicholas GM, Robert JG, et al. (2010) Operative versus nonoperative treatment of acute achilles tendon ruptures a multicenter randomized trial using accelerated functional rehabilitation. *J Bone Joint Surg Am* 92(17): 2767-2775.
- Christian Nordqvist (2014) Degenerative disc disease. Topic Overview, Back Pain Health Center, MNT.
- (2018) Spondylitis Association of America, USA.
- Abdullah Tashtoush (2016) Therapeutic degenerative disc disease (DDD) using disc rehabilitation table (DRT). *IEEE European Modelling Symposium*, pp. 51-56.



Creative Commons Attribution 4.0  
International License

For possible submissions Click Here

[Submit Article](#)

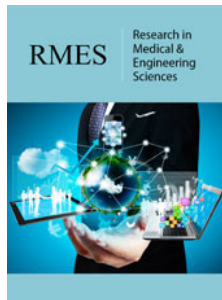

### Research in Medical & Engineering Sciences

#### Benefits of Publishing with us

- High-level peer review and editorial services
- Freely accessible online immediately upon publication
- Authors retain the copyright to their work
- Licensing it under a Creative Commons license
- Visibility through different online platforms